



YBM 10 T

YASDA PRECISION CENTER

Thermal Distortion Stabilizing System
High-performance Spindle with Preload Self-adjusting System
All axes Twin screw Drive System

Highly Accurate and Efficient Performance of YBM 10T

Outstanding Technology that enables the heaviest job on 1000x1000mm pallet in the world, of max. 5 tons with the highest accuracy

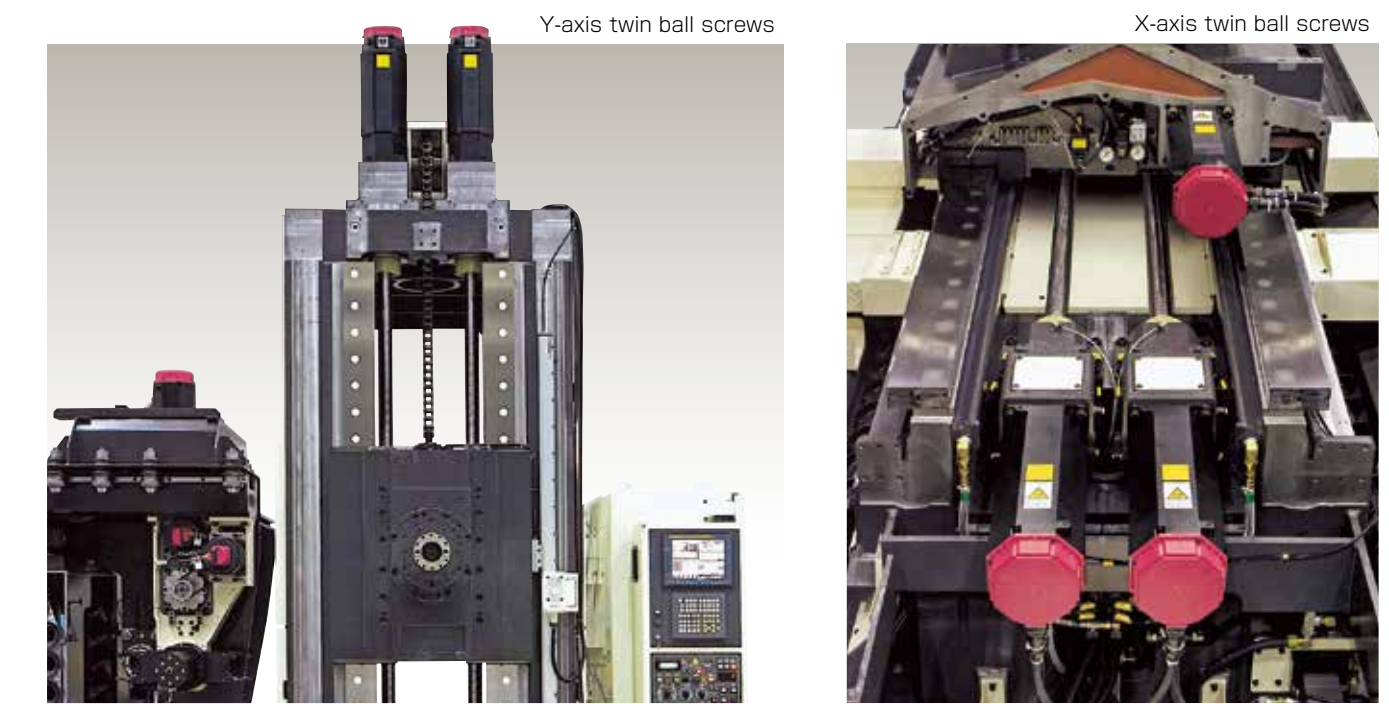
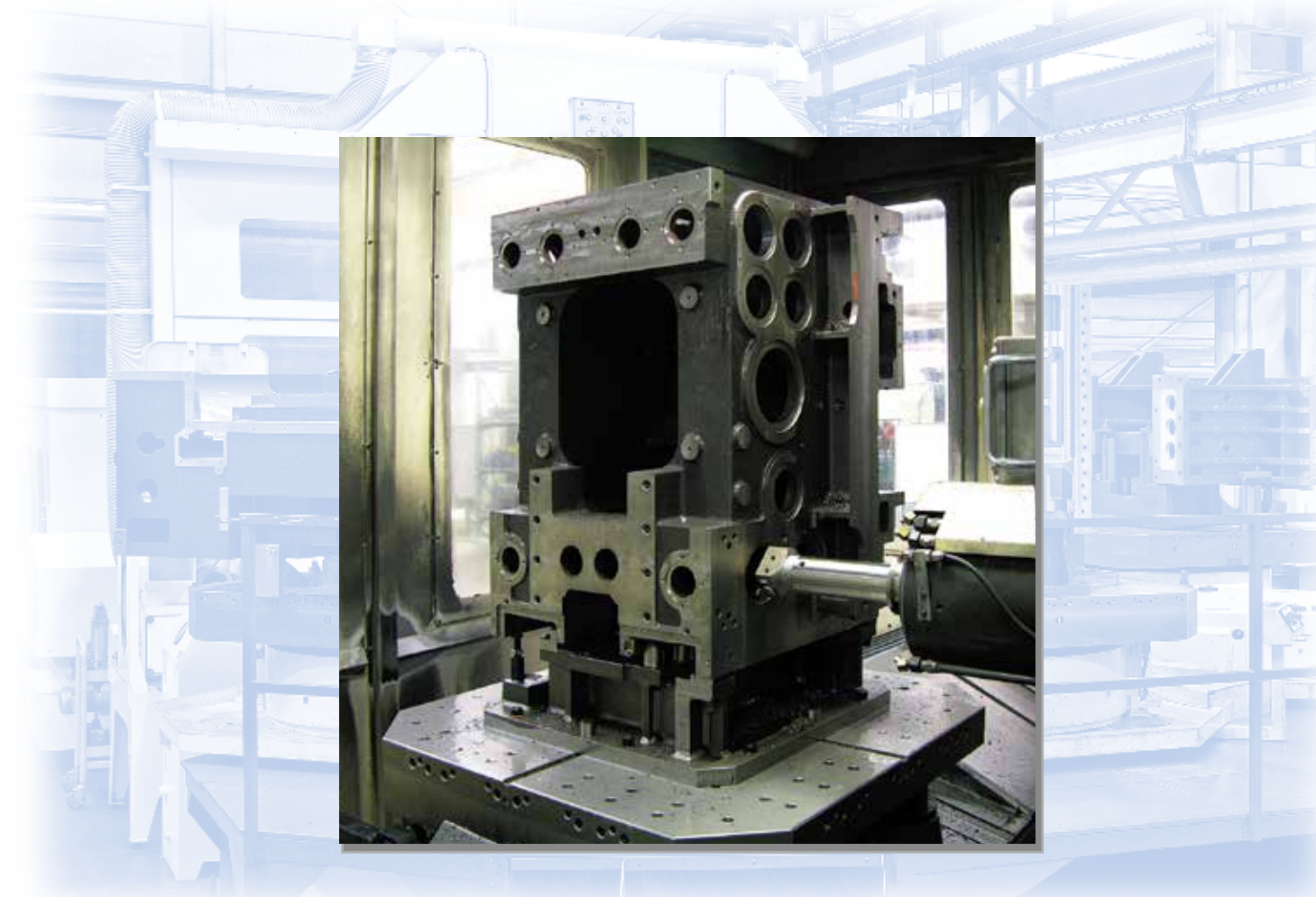

- 1 Twin ball screws (X/Y/Z axis)**
By using twin ball screws on each linear axis, high speed positioning of 45m/min. is achieved without sacrificing high positioning accuracy and machine rigidity.
- 2 B-axis employed big diameter 3 roller bearing**
By using the big diameter 3 roller bearing on B-axis highly accurate positioning of max. 5 tons on 1000x1000mm pallet rotation is achieved with high speed.
- 3 Improved vertical movement and straightness of the spindle head**
The spindle head is positioned in the center of the two ball screws that improved geometrical accuracy of Y-axis and stable vertical movement of the spindle head.
- 4 X-axis: Load sensing & Guide ways surface pressure control system**
In order to control a heavy component at high speed, the load sensing and guide ways surface pressure control system is employed on X-axis guide ways.

Best Quality and Performance

YASDA Precision Center YBM 10T is a large size horizontal machining center, developing a new area for high speed and high precision machining of a large and heavy components.

The high speed positioning of 45m/min. is achieved employing twin ball screws for each linear axis remaining YASDA's traditional high positioning accuracy and the machine further increased its rigidity.

Excellent capability is achieved for high precision machining of box shape components and large size die and molds.

Comparison of Previous model and YBM 10T

Work piece Saddle of vertical machining center		Machining time by previous model (hour)		Machining time by YBM 10T (hour)		Reduction of machining time in %
		YBM-120N-120RP-5PLS	YBM-10T-100RP-5PLS	YBM-120N-120RP-5PLS	YBM-10T-100RP-5PLS	
640Ver.Ⅲ	1st setting	4	3.2	20		
	2nd setting	10	9	10		
	3rd setting	5	4.3	14		

Work piece Table of vertical machining center		Machining time by previous model (hour)		Machining time by YBM 10T (hour)		Reduction of machining time in %
		YBM-120N-120RP-5PLS	YBM-10T-100RP-5PLS	YBM-120N-120RP-5PLS	YBM-10T-100RP-5PLS	
950Ver.Ⅲ		17.8	10.8	39		

— This data is a comparison in the Yasda workshop —

Positioning Accuracy

ISO 230/2(1988)				unit:mm
	X	Y	Z	
A (Positioning Uncertainty)	0.0035	0.0032	0.0029	

ISO 230/2(2014)				unit:mm
	X	Y	Z	
A (Positioning Uncertainty)	0.0030	0.0027	0.0026	

ISO 230/2(2014)				unit:mm
	X	Y	Z	
R (Repeatability)	0.0012	0.0008	0.0009	

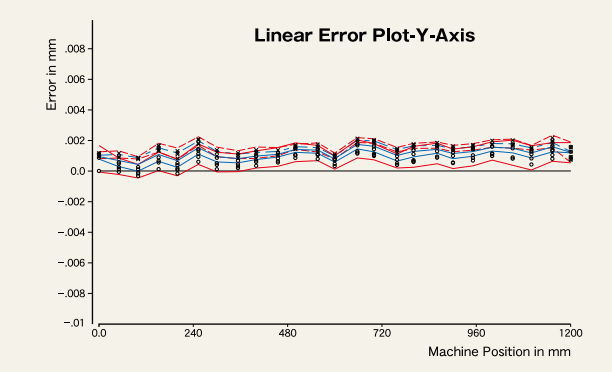

YASDA PRECISION CENTER
YBM 10T

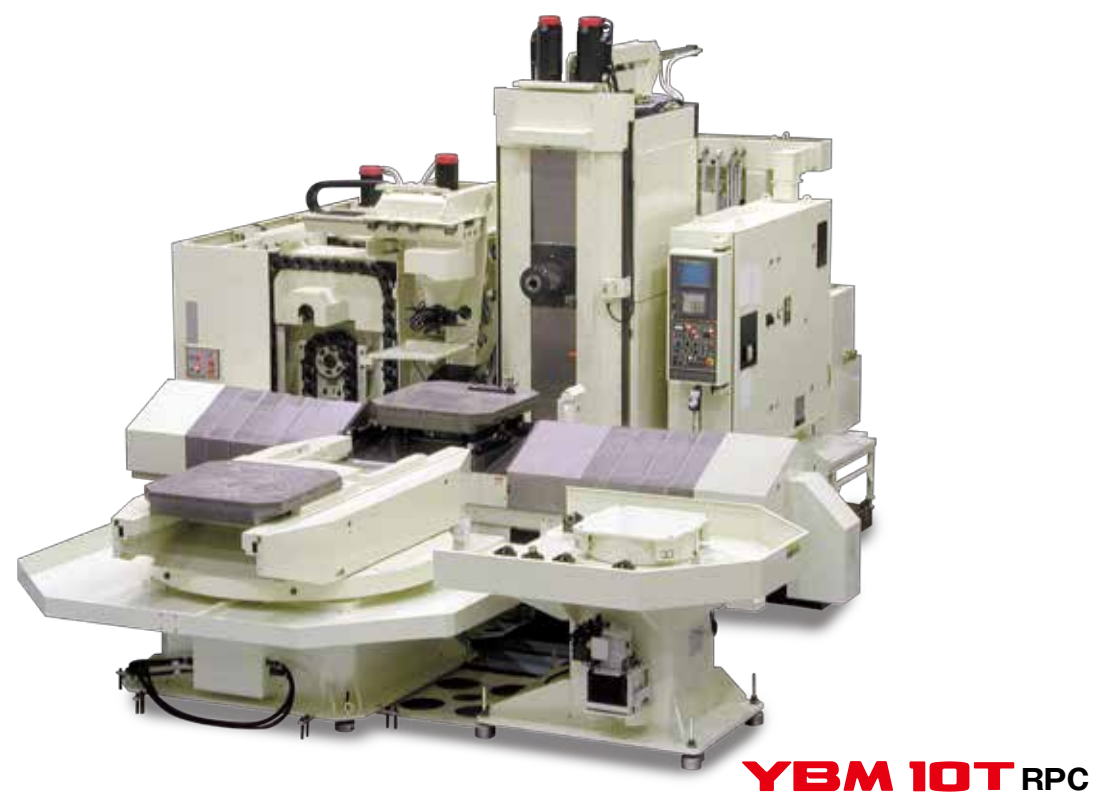

Highly rigid machine construction that supports reliability and stability of the precision job

BED

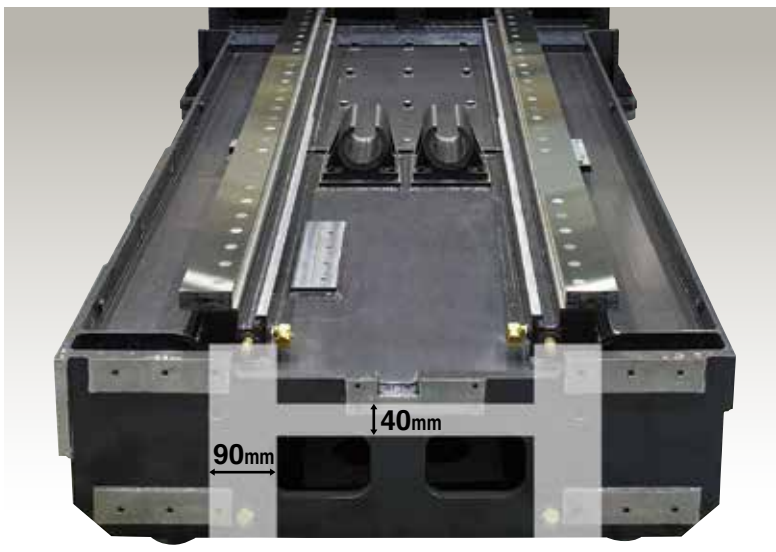

The steel bed of simple "H" configuration with two 90mm thick longitudinal frames and 40mm thick flat surface frame enabled outstanding rigidity. Each solid steel sheet of the frame has an equal heat capacity at any point, therefore the bed is free from any strain caused by the room temperature changes, and assure high stability of geometrical accuracy.

COLUMN

The large column with a double housing structure ensures outstanding thermal control and machine rigidity. Each housing is designed in the shape of box formed by double walls and ribs are arranged in the housing.

Column (Y-axis) guide ways

Y-axis guide ways are mounted in a slight concave configuration in order the spindle head to obtain equal preload at any position of Y-axis. Combination with the roller way bearings on the both sides of the spindle head, it minimizes yawing error of the spindle head and stable high positioning accuracy is ensured.

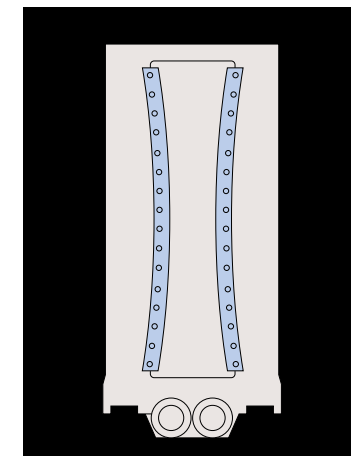

PALLET & PALLET CHUCKING SYSTEM

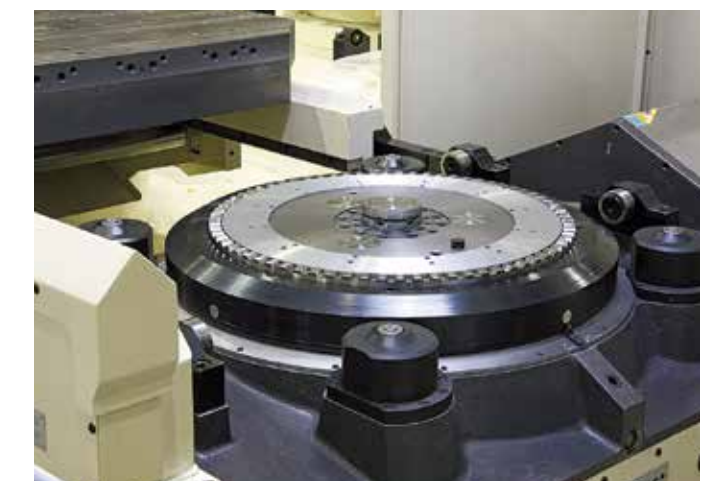
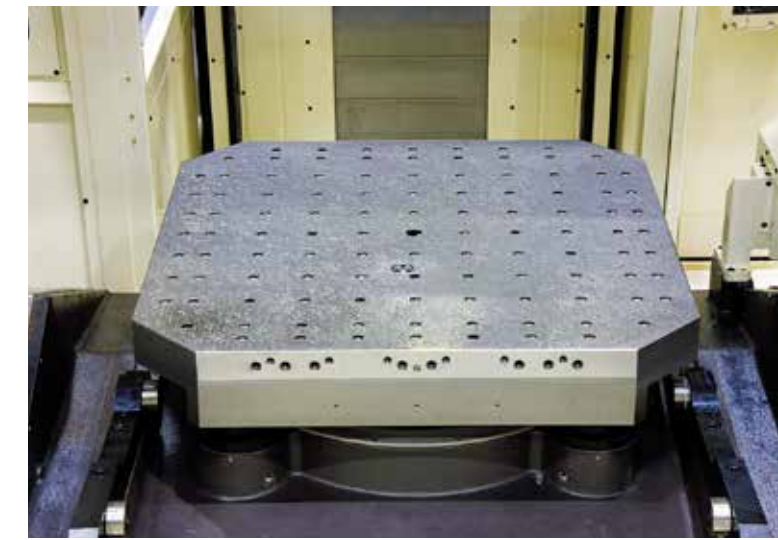

Highly rigid 120mm thickness pallet and the curvic coupling of large diameter ensure high accuracy of work pieces for long years.

- ①The pallet is made of high quality cast iron, and its top surface is carefully hand scraped to support micron meter accuracy of work piece.
- ②The bottom of the pallet is flat, and available for any kinds of transportation system, like automatic warehouse or FMS system.
- ③Large diameter curvic coupling is employed on the pallet chucking system. This curvic coupling has 72 teeth with a 30 degree engaging angle on each tooth which engage without any backlash and automatically locates the center of the pallet.

CLEANING NOZZLE FOR CURVIC COUPLING

Air cleaning nozzle is provided to the base of each tooth of the curvic coupling. The surface of the teeth is kept clean by ejected air from the nozzle, and it ensures high chucking accuracy all the time.



SPINDLE



YASDA's exclusive preload self-adjusting system technology provides a large preload at low speed, and reduces the preload according to the heat generated by higher spindle speed. This mechanism creates a clear advantage over the conventional fixed type preload system.

- ① Appropriate preload for full range of the spindle speed help achieve the both heavy duty cutting at low spindle speed and highly accurate rotation at high spindle speed.
- ② The spindle cartridge and the spindle motor are connected co-axially by a diaphragm coupling to achieve highly accurate rotation of the spindle at the full range of its rotation speed.
- ③ Variety of machining is possible by YASDA's spindle, such as highly accurate turn boring, heavy duty machining, high speed machining on the hardened steel, helical end milling, back face milling, and so on.

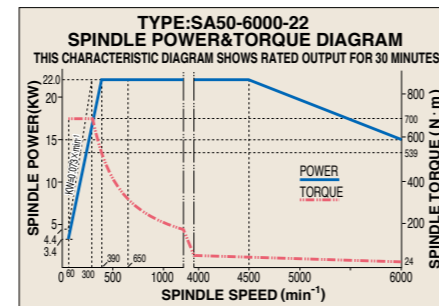
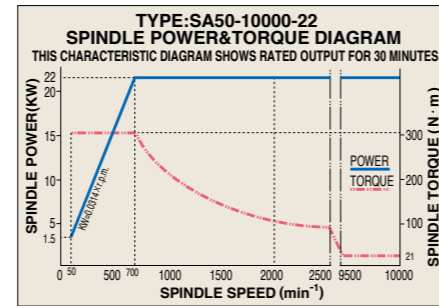

ATC



※Loading / unloading system of tool is option

Tool Stocker

From 120 tools up to 450 tools ATC is selectable according to the customer's purpose. Together with the Tool holder cleaning system, the reliable ATC proved its high stability at many users with their FMS systems for long years.



Automatic Tool Changer

OPTICAL SCALE FEEDBACK



OPTICAL SCALE FEEDBACK

The full closed loop type optical scale is employed for highly accurate positioning of linear axes. The scale is attached to the machine components in order not to create difference in temperature between the scale and the machine components.

ACCURACY RETENTION SYSTEM

THERMAL DISTORTION STABILIZING SYSTEM (Option)

Thermal distortion of the machine in geometry can occur when the room temperature changes in a short time, which is critical for high accuracy job.

YASDA Thermal distortion stabilizing system enables to keep the machine geometry stable against changes of the room temperature, that circulates a temperature controlled oil, $\pm 0.2^{\circ}\text{C}$ to room temperature, throughout the main structure of the machine.

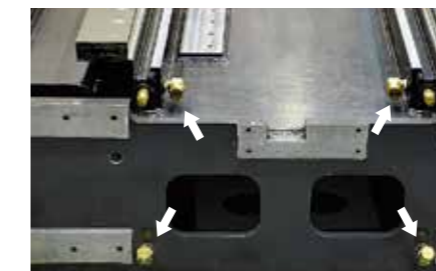

Thermal distortion stabilizing oil to the bed

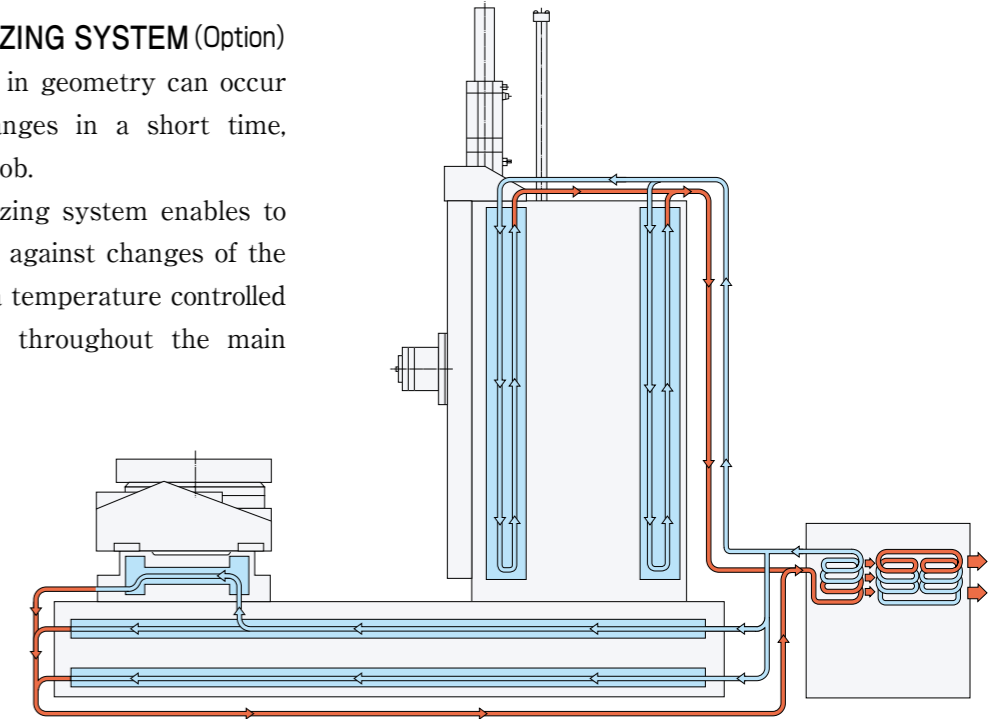

HEAT TRANSMISSION PREVENTION ON THE BED

The guide ways and the bed are protected with a cover so that the warmed coolant after machining and chips dropped cannot affect on the thermal deformation of these main components.

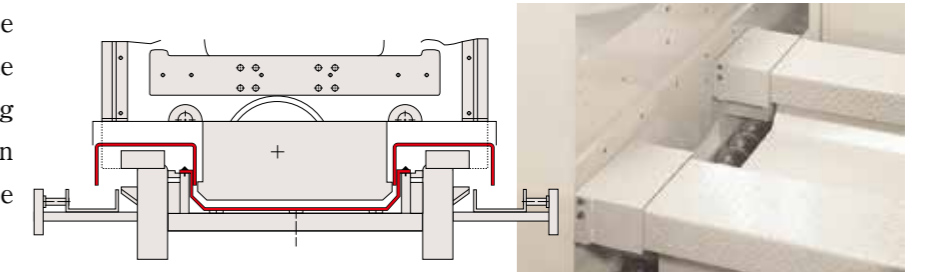

BALL SCREW BRACKET

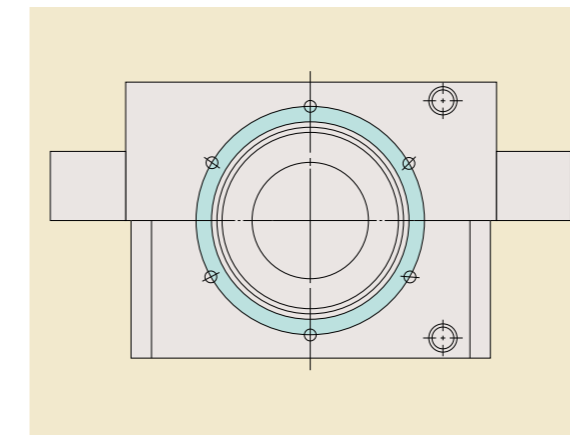

COOLING SYSTEM OF BALL SCREW BRACKET

Cooling oil circulates through the oil jacket in the ball screw bracket that prevents heat generation of the thrust bearing and helps stabilize machine geometry during its running.



OpeNe Version 2.0 serves as an intermediary between human and machine

Easier User Interface

Operation and functionality are improved by new FANUC IHMI

Touch-panel type 15-Inch display mounted with FANUC IHMI

A large-sized display with touch panel and the OpeNeVersion 2.0 provides intuitive operation. The manual viewer makes the FANUC instruction manual and machine user manual appear on the display.



HAS-4 realizes higher speed and higher precision machining

YASDA's high-precision machining function HAS-4, essential for machining molds, has 5 basic modes (M300 to M304) including rough machining and finish machining.

It is possible to reduce machining time and improve machining accuracy by changing parameters such as acceleration/deceleration and tolerance according to machining purpose.

On the machining assist screen, it is possible to select from 5 basic machining modes and to finely adjust machining parameters for each mode according to machining conditions. It is also possible to select smoothing and other functions on the screen, thus allowing optimal conditions to be established according to each type at machining including 3D-shaped mold machining and 5-axis machining. For HAS-4, machining time is reduced by eliminating the stop time between blocks and surface quality is improved by more finely controlling servo-control feedback signals.



Each function of OpeNe Version 2.0 provides the operator with complete details of the machine.



Tool Information Management



On this screen, not only basic tool information but also associated tool information such as machining load and measurement history are collectively managed. It is also possible to monitor spindle load in real time in comparison with past record data and check changes in same tool length and diameter. It is also possible to set a tool selected on the screen into the spindle {tool change} and tool measurement operation in interactive mode from the screen without program instructions.

Maintenance Management



On this screen, various data such as number of operations and running status of peripherals are automatically acquired and saved. Use of acquired data allows for planned and efficient maintenance and predictive maintenance on equipment. A check it current machine status is appropriate or not is carried out automatically by acquiring servo wave data and comparing it with past data.

Production Control



On this screen, not only machine running information but also mechanical information such as load on each axis while running, workpiece coordinates and tool compensation values are displayed. It is possible, in case of machining failure, to carry out a follow-up check because various types of mechanical information are displayed on the same time axis as that of program progress graph. It is also possible to graphically display actual machine running status on a daily, weekly and monthly basis. Machine running status data can be utilized in Excel format.

Work Management



The Work Management Function is an application for scheduling automated machining using AWC and APC. Cutting program can be registered to each workpiece and machining order can be flexibly scheduled on this application. This application helps increase production efficiency by the judgement function for judging whether each cutting program can be executed or not, machining time simulation function for calculating the total machining time of the whole process, etc.

SPECIFICATIONS

*Specifications are subject to alteration or change without notice and obligation on the part of the manufacturer.

1. Base machine specifications		
1) Travel	X-axis travel	1,500mm
	Y-axis travel	1,200mm
	Z-axis travel	1,100mm
	Table surface to spindle center distance	0~1,200mm
	Table center to spindle nose distance	200~1,300mm
2) Table(Pallet)	Pallet working size	1,000×1,000mm
	Pallet surface configuration	109-M16 tapped holes
	Loading capacity	5,000kg
	Min. table indexing angle	0.0001deg.
	Max.swing diameter of the workpiece	Φ1,350mm
	Max.workpiece size on the pallet	Φ1,350mm
	Max. height of the workpiece	1,500mm
3) Spindle	Spindle type	SA50-10000-22 Preload self-adjusting spindle
	Spindle speed range	50~10,000min ⁻¹
	Spindle drive motor	AC18.5kW/22kW (Continuous/30min)
	Spindle taper hole	MAS BT50
	Spindle bearing inner diameter	Φ100mm
	Spindle nose surface	BIG plus spindle
	Rapid feed	(X-,Y-,Z-axis) Max.45,000mm/min (B-axis) Max.10min ⁻¹
4) Feed rate	Cutting feed	(X-,Y-,Z-axis) Max.10,000mm/min (B-axis) Max.4min ⁻¹
	Min.input increment	0.0001mm(deg.)
5) ATC	Tool shank type	MAS BT50
	Pull stud type	MAS403 P50T-1
	Tool storage capacity	60 tools/120 tools stand
	Max. tool dia./length/mass	Φ400mm(with limitation) /550mm/20kg
	Max.tool diameter in full setting	Φ100mm
6) Automatic pallet changer(APC)	Tool selection system	Shortcut random selection
	Method of pallet change	Rotary shuttle
	Number of pallets	2 pallets
	Set-up station	1station
7) Pallet chucking device	Diameter of curvic coupling	Φ600mm
8) Mass of machine(without ATC magazine)		Approx.30,000kg
9) Electric power capacity		Max.105kVA
10) NC unit		FANUC 31i-B5

2. Standard equipments

1) Optical scale feed back		X-,Y-,Z-axis 0.0001mm command available
2) Rotary encoder feedback		B-axis 0.0001deg. command compliant
3) Hydraulic unit	Pump discharge pressure/Oil reservoir	9MPa/100L
4) Oil cooling system for spindle head, spindle motor and ball screw brackets		
5) Coolant unit	AA type	6 built-in nozzles
	Pump discharge	0.3MPa, 30L/min
	Tank capacity	1,850L
6) Splash guard		Manual slide door with ceiling cover ,4 LED lights
7) Chip conveyor		Screw conveyor (inside the machine) + scraper chip conveyor with separator (outside the machine)
8) Guide way protector		
9) Automatic power breaker		
10) 3-layer signal light		Red,yellow,green (Flashing)
11) OpeNe Version2.0		

3. CNC standards

1) Display		15"LCD touch panel with iHMI
2) Program memory capacity		512KB (1280m)
3) Custom macro common variable		600
4) Number of registerable programs		1,000
5) Automatic corner override		
6) Tool offset pairs		64 pairs
7) Tool offset memory		Memory C
8) Extended part program editing		
9) Background editing		
10) Memory card/USB memory interface		Data input/output

4. Optional equipments

1) High-torque spindle	Spindle type	SA50-6000-37 Preload self-adjusting spindle
	Spindle speed range	60~6,000min ⁻¹
	Spindle drive motor	AC30kW/37kW (Continuous/30min)
	Spindle taper hole	MAS BT50
	Spindle bearing inner diameter	Φ110mm

4. Optional equipments

2) High-speed spindle	Spindle type	SA50-15000-30 Preload self-adjusting spindle
	Spindle speed range	50~15,000min ⁻¹
	Spindle drive motor	AC26kW/30kW (Continuous/60%ED)
	Spindle taper hole	MAS BT50
	Spindle bearing inner diameter	Φ90mm
3) Preload stand (PLS)	Number of stands	5PLS
	Automatic program search	
4) Multiple magazine (with ATC)	Tool storage capacity	90~450 tools
	Max. tool dia./length/mass	Φ400mm(with limitation) /440mm,550mm (No.1 magazine only) /20kg
	Max.tool diameter in full setting	Φ100mm
	Tool selection system	Shortcut random selection
5) Stroke extension	X-axis	600mm/total 2,100mm
	Y-axis	200mm/total 1,400mm
	Z-axis	300mm/total 1,400mm
6) Thermal distortion stabilizing system		With weekly timer
7) Coolant temperature controller		
8) Shower coolant unit		Celling shower
9) Spindle center through flood coolant	Pump discharge pressure	3.5MPa/6MPa
	Pump discharge amount	20L/min
10) Spindle center through micro fog coolant		
11) External mist coolant		2 nozzles around the spindle
12) Oil skimmer		
13) Mist collector		
14) Tool measurement & Tool breakage detection system		LP2(by Renishaw) NT-H (by BLUM)
15) Automatic workpiece measuring system		Touch prove OMP60(by RENISHAW)
16) High-speed machining function (YASDA HAS-4 system)		With Machining support screen
17) Weekly timer		
18) Compensation for spindle thermal displacement		Individual data
19) Signal tower (Multilayer signal lamp)		Red,yellow,green(Flashing)
20) Washing gun		
21) Chip bucket		
22) Anchor unit		
23) Automatic fire-extinguishing equipment interface		

5. CNC options

1) Part program storage	Total :1MB,2MB,4MB,8MB
2) Number of registerable programs	Total:2,000, 4,000
3) Herical interpolation	G02 · G03
4) Inch/metric conversion	G20 · G21
5) Scaling	G50 · G51
6) Coordinate system rotation	G68 · G69
7) Programmable mirror image	G50.1 · G51.1
8) Optional block skip	Total :9
9) Tool offset pairs	Total: 99,200,400,499,999pairs
10) Addition of workpiece coordinate pair	48pairs,300pairs
11) Tool management function	
12) Normal direction control	G40.1 · G41.1 · G42.1
13) Cs countouring control	
14) High-speed smooth TCP	G43.4 · G43.5
15) Tilted working plane command with guidance	G68.2 · G69 · G53.1
16) Workpiece setting error compensation	G54.4Pn
17) Ethernet function	FOCAS2/Ethenet
18) Data server function	Fast data server,Capacity:1GB,2GB,4GB,16GB,32GB

OUT LINE

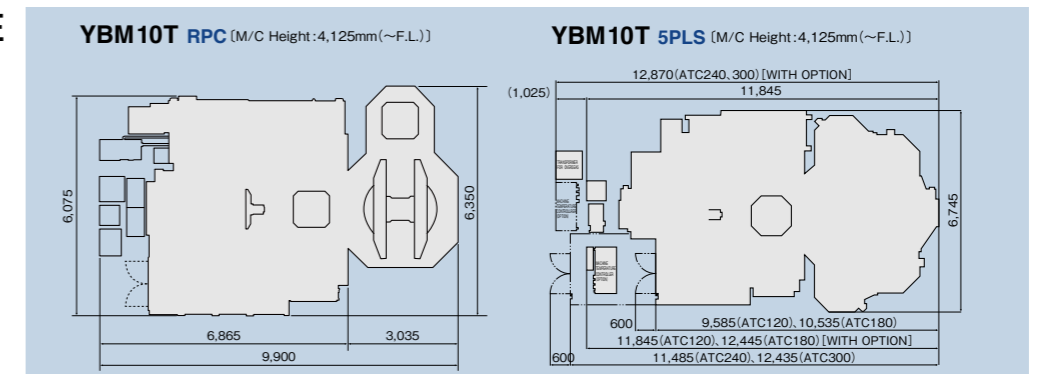



YASDA PRECISION TOOLS K.K. www.yasda.co.jp

Head Office & Factory

1160 Hamanaka, Satosho, Okayama, 719-0303, Japan
TEL:+81/865-64-2511 FAX:+81/865-64-4535

Representative Office

Schiessstr.35, D-40549 Düsseldorf Germany
TEL:+49/211-598937-40 FAX:+49/211-598937-50

YASDA PRECISION AMERICA CORPORATION

62 North Lively Boulevard Elk Grove Village, IL 60007 U.S.A
TEL:+1/847-439-0201 FAX:+1/847-439-0260

YASDA PRECISION TOOLS (SHANGHAI)

Room.1001 Crient Intemational Plaza Part(C) No.85 Lou Shan Guan Rd.,Shanghai, 200336, China
TEL:+86/21-62700955 FAX:+86/21-62700970

YASDA PRECISION TOOLS (SHANGHAI) Dongguan Office

5A Xingye Buillding No.89,Lianfeng Rd.,Changan Town, Dougguan City,Guangdong, 523850, China
TEL:+86/769-82283036 FAX:+86/769-82283086

YASDA PRECISION TOOLS (SHANGHAI) Dalian Office

Room.707 Rongtong Plaza No.73,Liaohe west Rd.,Dalian Economic Development Zone,Liaoning, 116600, China
TEL:+86/411-39219865 FAX:+86/411-39219865