

YMC650+RT20

YASDA's tilting rotary table, realizing highly accurate 5-axis micro machining of larger work.

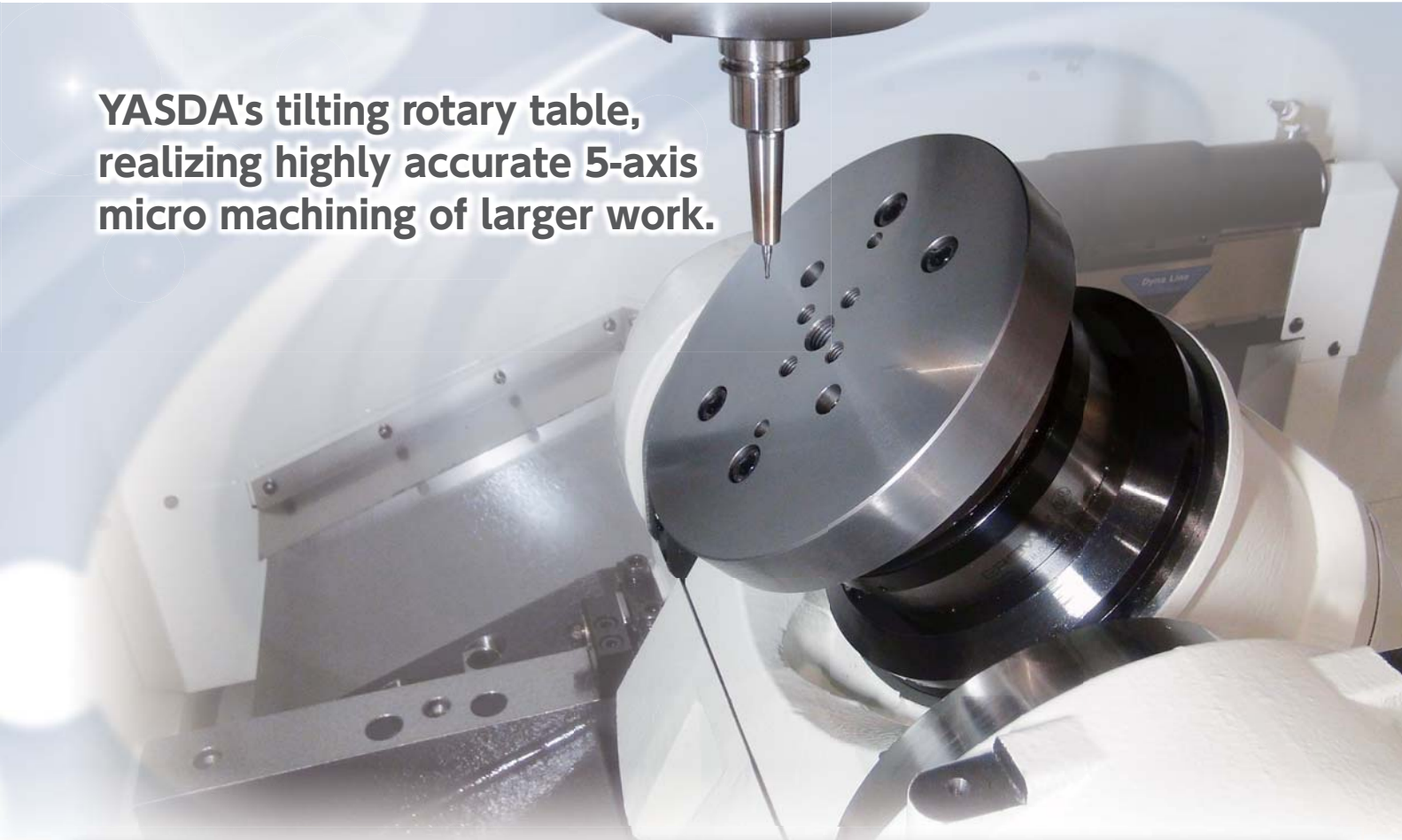

- The high precision micro machining center, YMC650 equipped with a DD(Direct Drive) motor-driven high precision tilting rotary table.
- By having a new larger table surface, RT20 can hold a workpiece up to $\phi 330\text{mm}$

Rotary axis indexing accuracy

ISO 230-2 (1997)

unit(sec)

	B	C
Accuracy: A	1.20	1.12

Circularity of tilted cone shape machining

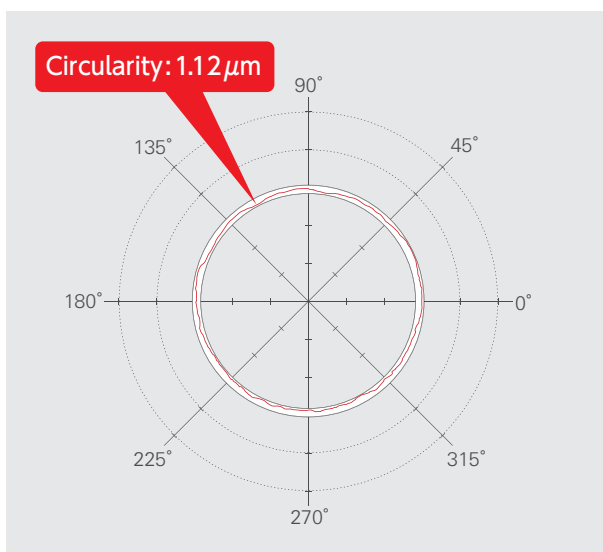

RT20 SPECIFICATIONS

RT20 main specifications	
Table tilting(B-axis)	-10 ~ 100deg
Table rotation(C-axis)	360deg (Continuous)
Distance from tilting axis center to spindle nose face	175 ~ 455 mm
B/C-axis maximum rotation speed	100min ⁻¹
Pallet loading capacity	35kg (including pallet)
Minimum input increment	0.00001 deg
Chucking system	EROWA power chuck(ER-029436) system 3R macro magnum(3R-SP26712)

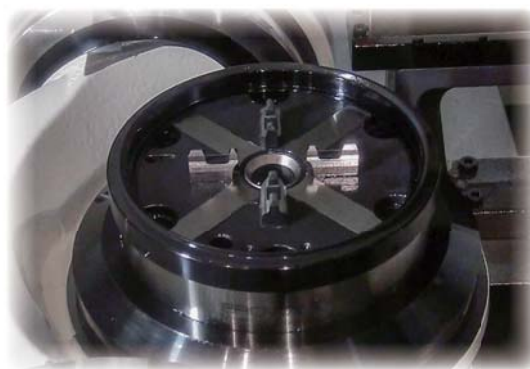

EROWA power chuck P

DIMENSION

Each chacking system's dimensions

		EROWA	system 3R
Workpiece dimensions	Pallet	ER-041912	3R-681,156-A
	A	242	247
	B	163	168
Table dimensions	ϕD	148	156
	E	116	110.3
	F	59	64.7

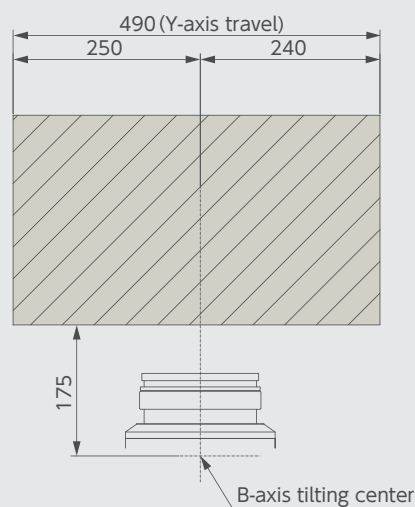
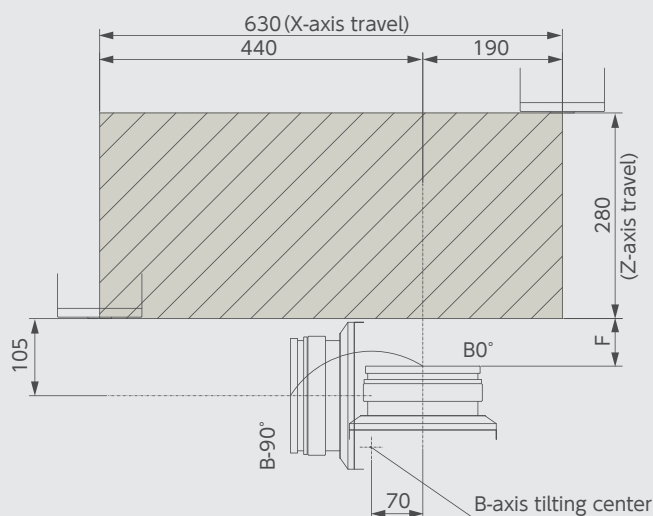
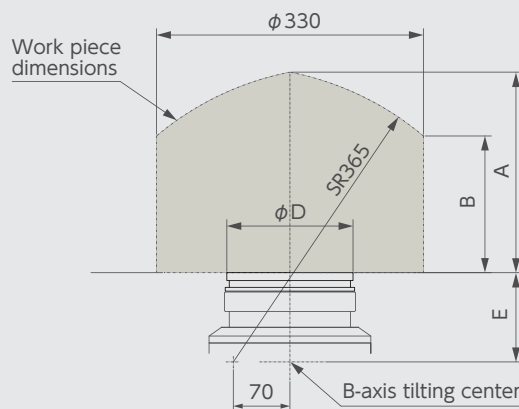

YASDA PRECISION TOOLS K.K.

www.yasda.co.jp

Main Office & Factory:

1160Hamanaka,Satosho-cho,Okayama,719-0303,Japan
PHONE: +81/865-64-2511 FAX:+81/865-64-4535

Representative Office:

Schiesstr. 35, D-40549 Düsseldorf Germany
PHONE: +49/211-598937-40 FAX: +49/211-598937-50

YASDA PRECISION AMERICA CORPORATION

62 North Lively Boulevard, Elk Grove Village, IL 60007, U.S.A.
PHONE: +1/847-439-0201 FAX: +1/847-439-0260

YASDA PRECISION TOOLS (SHANGHAI)

Room. 1001 Orient International Plaza Part(C),
No.85 Lou Shan Guan Road, Shanghai, 200336, China
PHONE: +86/21-62700955 FAX: +86/21-62700970

Dongguan Office:

5A Xingye Building, No.89.Lianfeng Road,
Changan Town, Dongguan City, Guangdong, 523850, China
PHONE: +86/769-82283036 FAX: +86/769-82283086