

Aiming for the best, not the biggest.

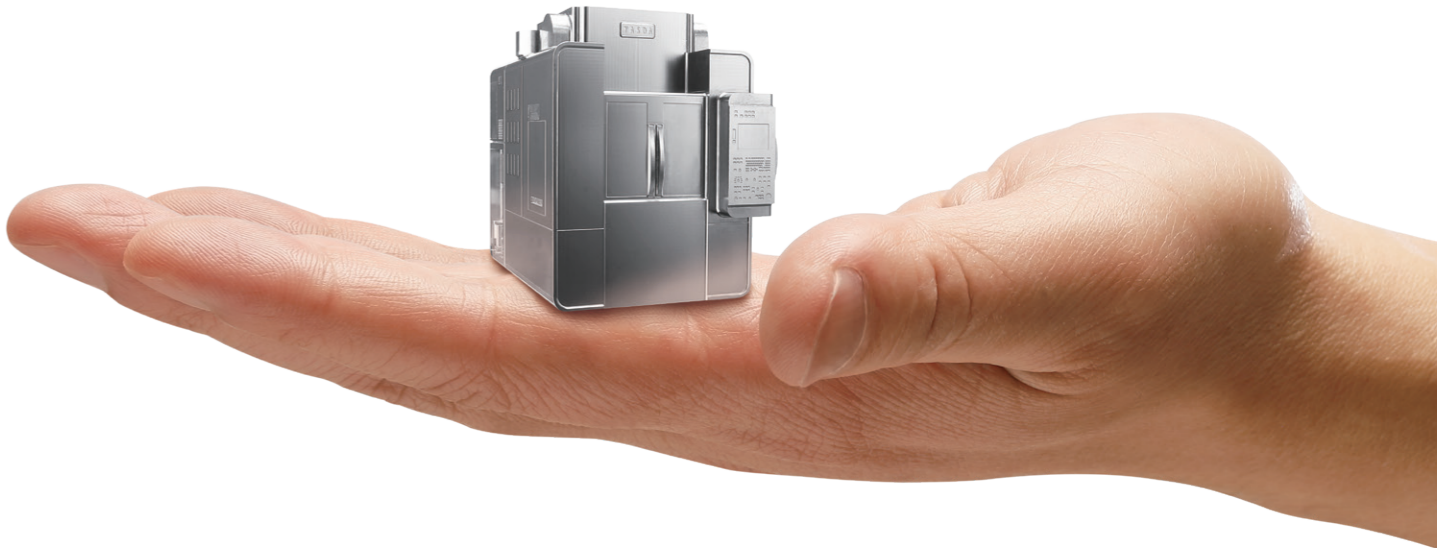

YASDA PRECISION TOOLS K.K. www.yasda.co.jp

< Head Office and Factory >

1160 Hamanaka, Satosho, Okayama, 719-0303, Japan
TEL: +81/865-64-2511 FAX: +81/865-64-4535

Representative Office

Schiessstr. 35, D-40549 Düsseldorf Germany
TEL: +49/211-598937-40 FAX: +49/211-598937-50

YASDA PRECISION AMERICA CORPORATION

62 North Lively Boulevard Elk Grove Village, IL 60007 U.S.A
TEL: +1/847-439-0201 FAX: +1/847-439-0260

YASDA PRECISION TOOLS (SHANGHAI)

Room.1001 Orient International Plaza Part(C) No. 85 Lou Shan Guan Rd., Shanghai, 200336, China
TEL: +86/21-62700955 FAX: +86/21-62700970

YASDA PRECISION TOOLS (SHANGHAI) Dongguan Office

5A Xingye Building No. 89, Lianfeng Rd., Changan Town, Dongguan City, Guangdong, 523850, China
TEL: +86/769-82283036 FAX: +86/769-82283086

YASDA PRECISION TOOLS (SHANGHAI) Dalian Office

Room.707 Rongtong Plaza No. 73, Liaohe west Rd., Dalian Economic Development Zone, Liaoning, 116600, China
TEL: +86/411-39219865 FAX: +86/411-39219865



COMPANY PROFILE

The “KODAWARI” to be an industry leader

Nearly a century has passed since my grandfather, Shinjiro Yasuda, established YASDA in 1929. And thanks to the support of many people, we have grown to become a well-known machine tool and machining center manufacturer that lists global companies among its customers.

YASDA began as a small neighborhood boring and machining factory with only three employees. Since then, we and our products have evolved from making pistons for automobile engines to making high-precision machining centers.

The YASDA of today is a product of technological improvements developed to meet and surpass our customer expectations. As requirements and the level of precision has improved to more sophisticated and difficult processes, we have evolved to meet those challenges.

It would not be an overstatement to say that the evolution of YASDA is the product of disciplined responses to the continuously changing needs of industries.

Today, the world is entering a new era and undergoing a variety of different and additional changes. Including the shift from gasoline to electric vehicles (EVs), an evolution of medical technologies, smaller and smaller electronics and communication devices, new lighter aircraft, advances in aerospace, and the development of new materials.

At YASDA we do not fear the future and will continue to make the necessary reforms and updates to respond to the various changing needs of our customers around the world.

YASDA’s “KODAWARI” in the pursuit of even greater precision and more advanced technologies, also extends to our dedication to support manufacturing and be a trusted partner to our customers, many of whom are taking the lead in cutting-edge technologies in their sectors. It is our “KODAWARI” to work tirelessly to continually provide the best products, technical advice, and support in machining technologies to help our customers push the envelope of what is possible.

“Aiming for the best, not the biggest.”

This unyielding slogan represents the YASDA spirit, YASDA’s “KODAWARI,” that all YASDA employees are committed to, aiming for quality over quantity and to evolving for the future to be and continue to be an industry leader.



President

Takuto Yasuda

安田 拓人

Aiming for the best, not the biggest.

At YASDA our “KODAWARI” is to pursue the highest level of precision and services. We work tirelessly to provide new solutions for ever-evolving industries.

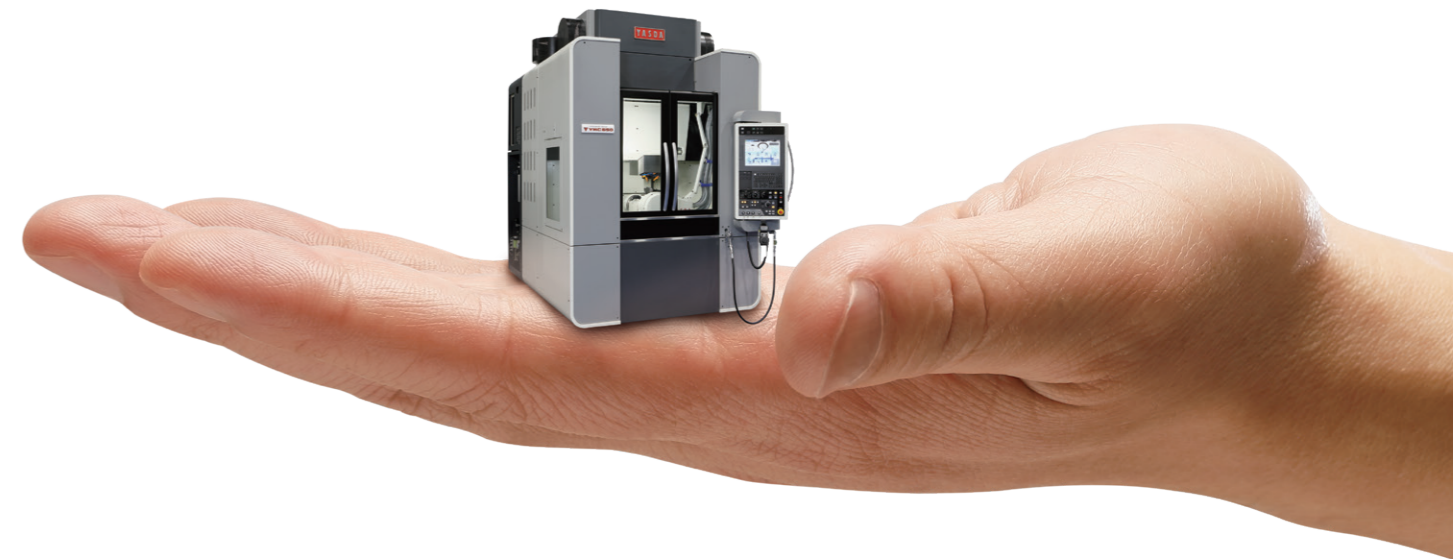

“KODAWARI” in Precision and Technologies

The meaning of the Japanese word “KODAWARI” will vary depending on the context, at YASDA it is used to describe an “uncompromising will” or “obsessive determination” to not compromise on quality, precision, and technology.

Contents

P02 President’s Message	P13 — YASDA Craftsmanship
P04 YASDA’s “KODAWARI” to innovate world manufacturing	P14 YASDA Ultra high-precision
P06 “KODAWARI” in Environment	P16 “KODAWARI” for the future
P08 “KODAWARI” in Precision Technologies	P18 — New Challenges
P10 — Design and Development	P19 — “KODAWARI” for Customer Support
P11 — Manufacturing	P20 Our Growing Service Network
P12 — Measurement	P22 Japan Offices and access

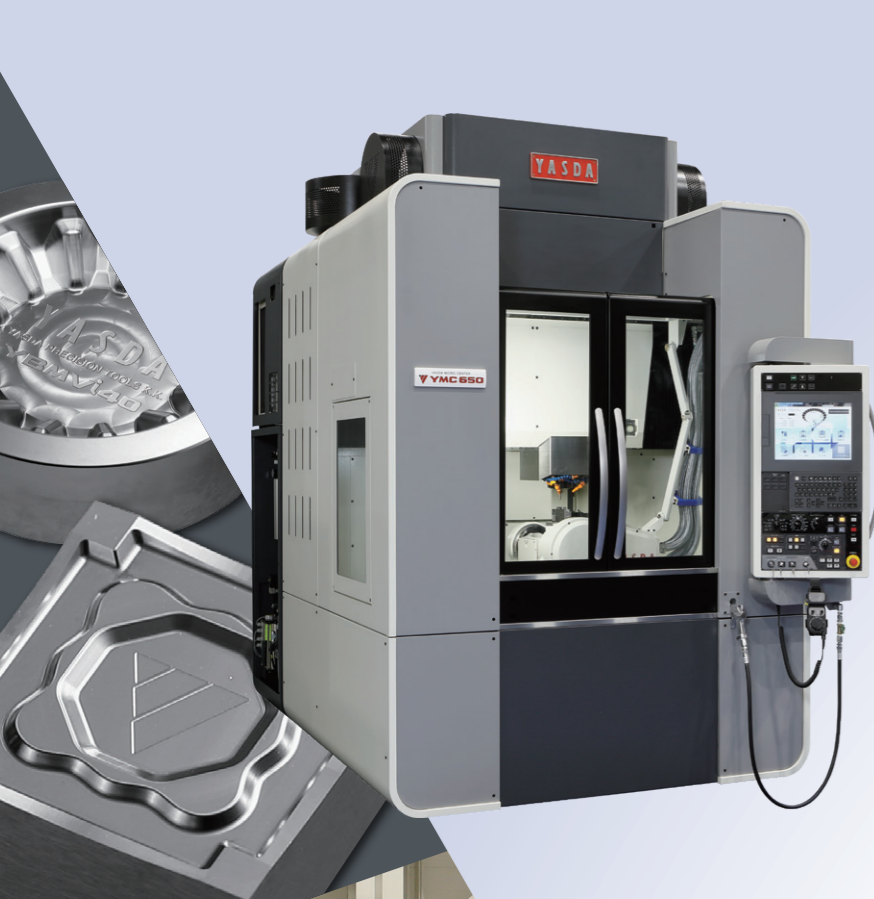

YASDA's "KODAWARI" to innovate world manufacturing.

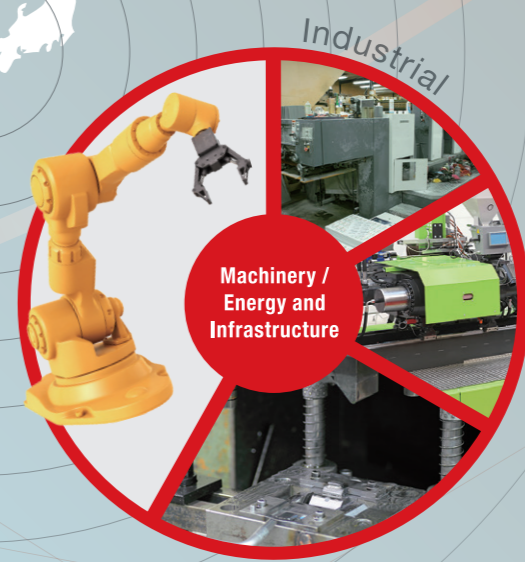

YASDA supports manufacturing around the world, providing high-quality, high-precision YASDA solutions to the cutting edge of technology using its ultra-high-precision machining systems.

“KODAWARI” in Environment

PRODUCTION ENVIRONMENT

Integrated Production Environment

One of the clearest examples of our “KODAWARI” for manufacturing is our integrated production environment. Our functionally designed head office leads into our temperature controlled factory buildings with streamlined manufacturing processes for YASDA machines and products.

 Solar

Machining



Main Office



Industrial machine machining

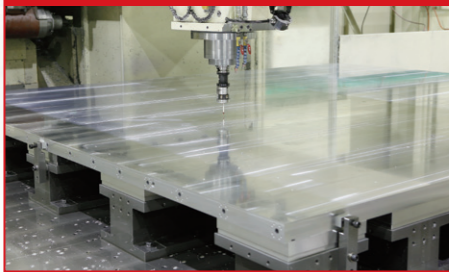

Assembly Cleanroom

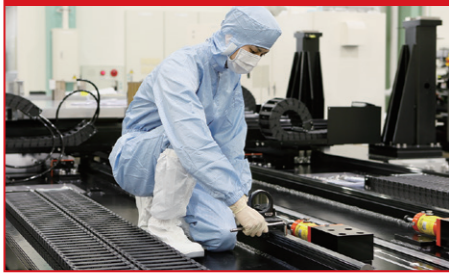

 Assembly
(Constant Temperature Controlled Areas)



Sheet Metal



Showroom



“KODAWARI” in Precision and Technology

KODAWARI **01**
Design and Development



KODAWARI **02**
Manufacturing



KODAWARI **03**
Measurement



KODAWARI **04**
YASDA
Craftsmanship





Design and Development

“KODAWARI” in Design and Development

At YASDA we have a three-directional approach to developing leading and innovative machine technology; Ultra-high Precision, Advanced Automation, and Multifunction. We are committed to the development and production of reliable high-precision machining centers that continue to support cutting-edge industries now and in the future.



“KODAWARI” in Technology

Self-adjusting Preload Spindle

YASDA's “KODAWARI” to provide our customers with a spindle that could do both heavy-duty cutting and high-precision finishing, led to the development of the self-adjusting preload spindle. This unique system self-adjusts as the bearings heat up to allow the spindle to maintain the same amount of preload at all speeds over the entire speed range.

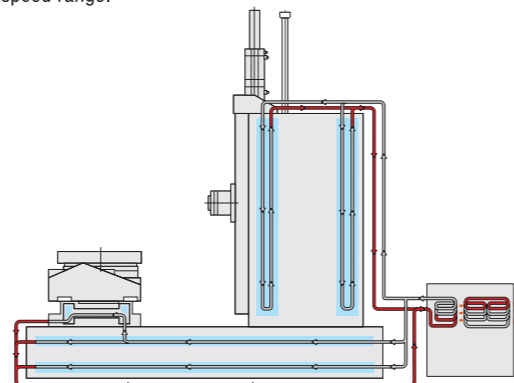
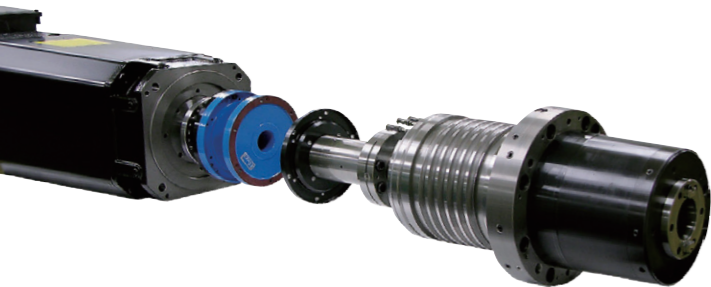

Thermal Deformation Stabilizing System

YASDA's one of a kind Thermal Deformation Stabilizing System is an advanced temperature control system that works to control the temperature of the machine for optimal performance and precision. This system works to cool the machine during operation to eliminate thermal deformation that would affect the precision of the machine, even in factory environments that are not air-conditioned.



■ Spindle assembly room (cleanroom)



■ Spindle function test

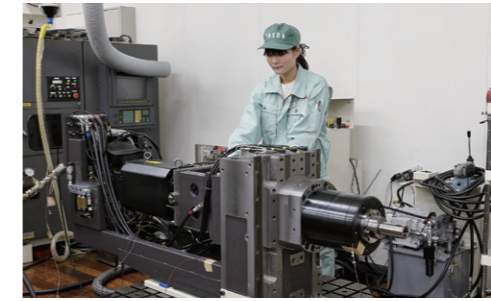

■ Machining



YASDA's “KODAWARI” in Manufacturing Environment

Our assembly factories were built with vibration elimination systems and fitted with temperature management systems that maintain a constant temperature within +/- 0.5 degrees all year-round to ensure high precision manufacturing.

In the main factory, we produce our ultra-high precision machinery, where all of the highest precision components, are machined by our machines.

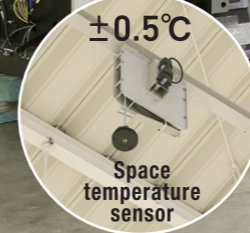

Constant temperature assembly factory

Manufacturing

The temperature is strictly controlled to maintain $20^{\circ}\text{C} \pm 0.3^{\circ}\text{C}$



Measurement

High-precision measurement room

“KODAWARI” in Measurement

The pursuit of sub-micrometer precision

The only way to achieve true sub-micrometer accuracy and precision is if you can measure it. In our high-precision measuring room, we use ultra-precise measuring technology to ensure that all YASDA produced components are accurate to sub-micrometer levels.

Roundness measuring system

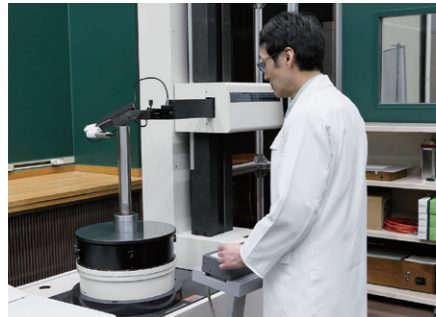

3D measurement system

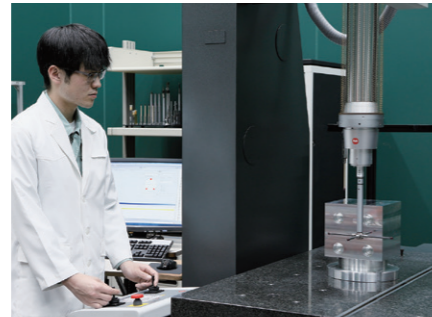

Step gauge

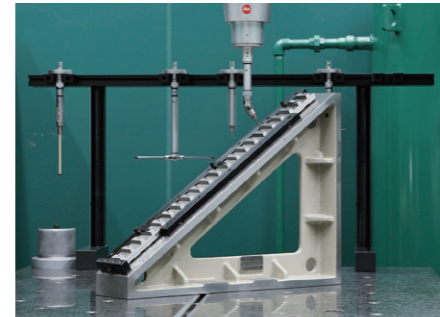

Measuring at different process stages

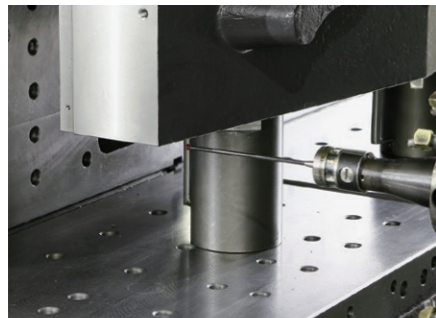

Machining



Assembly



Hand-scraping

Hand-scraping the ultimate “KODAWARI”

No other part of our production process embodies our “KODAWARI” for the pursuit of perfection than hand-scraping. Our expert hand-scrapers meticulously scrape each surface with sub-micrometer precision to ensure components not only attain, but will continue to maintain the highest possible precision over the life of the machine.

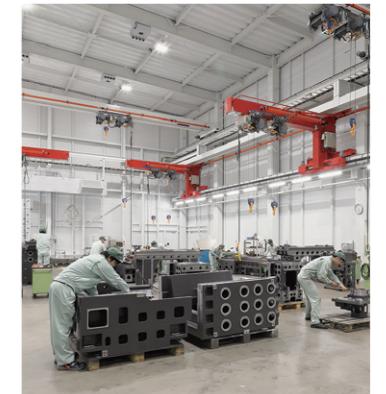

The right angles of each spindle housing are hand-scraped to the highest precision.

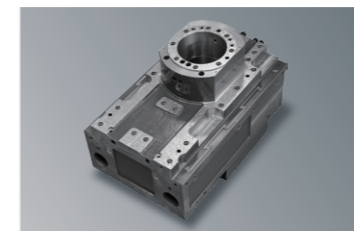

The Hand-scraping Process

Rub with a high-precision surface plate

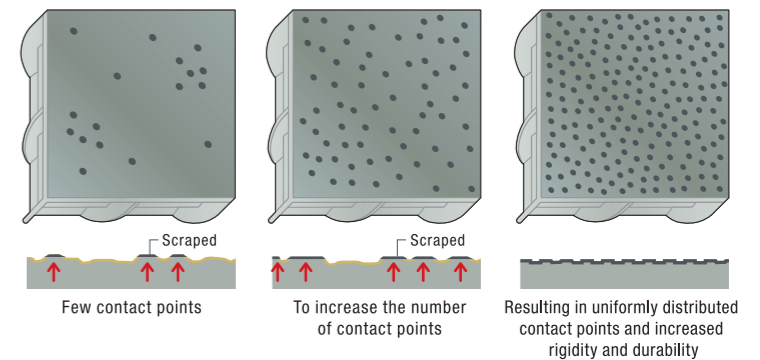
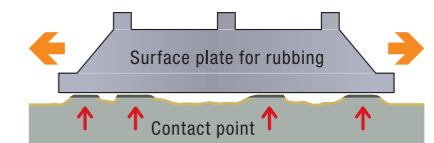

YASDA Ultra high-precision

Some Ultra high-precision examples of what
YASDA machines make possible.

HIGH-PRECISION
MACHINING

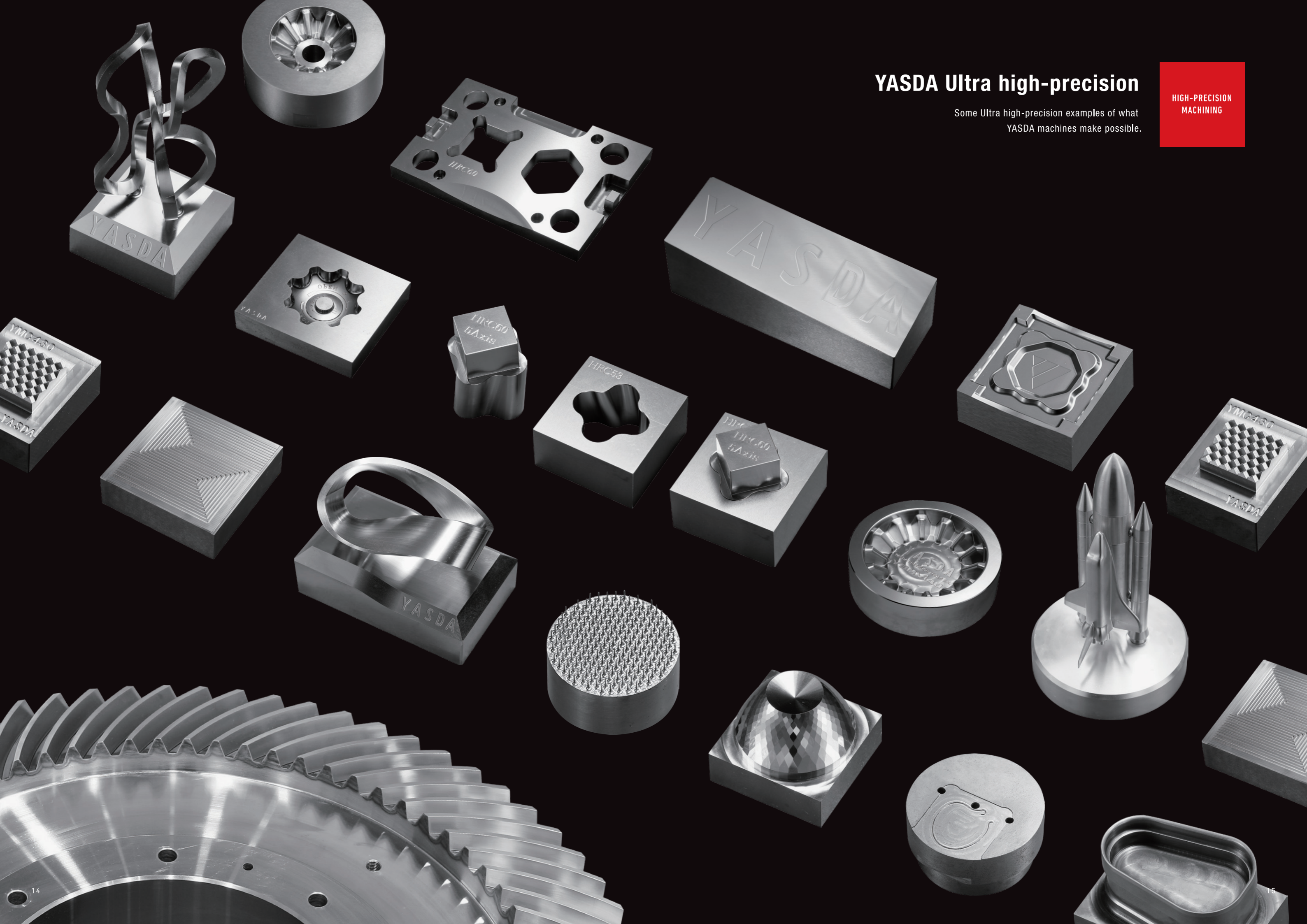

KODAWARI **01**
New Challenges

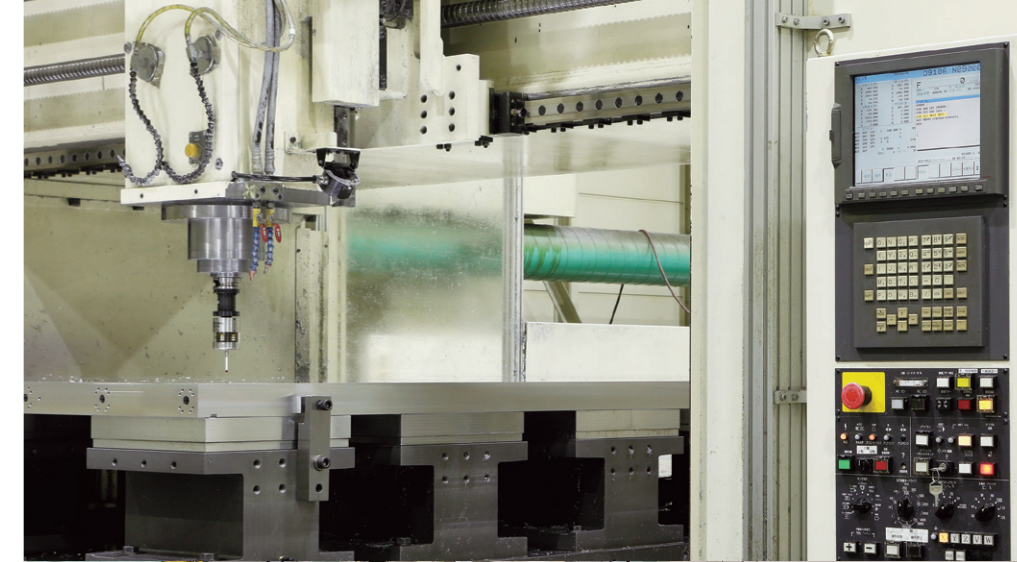

“KODAWARI”
for the Future



KODAWARI **02**
Services





New Challenges

Cleanroom

Venturing into new fields

Our “KODAWARI” to manufacture the highest-level machining centers in the world has led YASDA to develop and acquire many fundamental technologies and know-how. To further our growth potential, we have also been manufacturing devices related to semiconductors and liquid crystals (in a specialized assembly cleanroom). Our “KODAWARI” drives us to seek out new challenges, in new fields, so that we can expand YASDA’s potential now and in the future.

Specialized Assembly cleanroom



Industrial machine machining factory

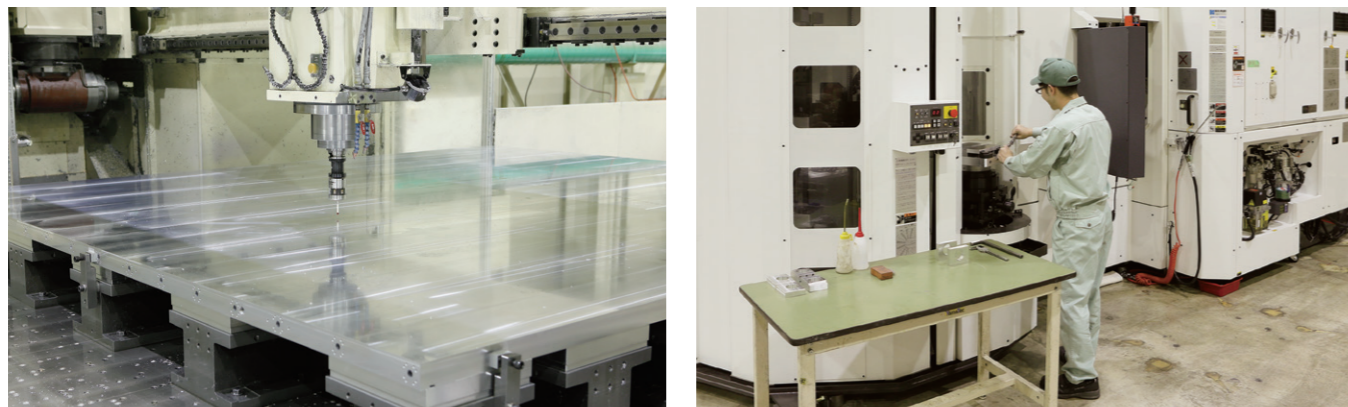

“KODAWARI” for Customer Support

At YASDA our service does not end after we deliver and install the machine. YASDA’s “KODAWARI” for customer support drives us to go beyond initial machine performance requirements. Our comprehensive support also extends to; assisting with the preparation of the installation environment; offering technical machining advice and support; working closely with our customers to assist with machine maintenance, and providing consultation on machine upgrades as requirements change. YASDA’s “KODAWARI” is to provide total support.

Showroom



Maintenance



Seminars



Service

SERVICE NETWORK

Our growing Service Network

We are expanding our network around the world

01 HEAD OFFICE and FACTORY

02 GERMANY OFFICE

03 THAILAND OFFICE

04 YASDA PRECISION AMERICA CORPORATION

05 YASDA PRECISION TOOLS (SHANGHAI)

06 YASDA PRECISION TOOLS (SHANGHAI) DALIAN OFFICE

07 YASDA PRECISION TOOLS (SHANGHAI) DONGGUAN OFFICE



Office / Local subsidiary / Service base Agents

**BUSINESS BASES
IN JAPAN**



- 01** HEAD OFFICE and FACTORY
- 02** OSAKA OFFICE
- 03** NAGOYA OFFICE
- 04** NAGANO OFFICE
- 05** KANTO OFFICE
- 06** SENDAI OFFICE



エコアクション21
Certification number:
0000724

The entire YASDA Precision Tools is practicing eco-actions.

ACCESS

- About 5-minute drive from Satosho Station of the Sanyo Main Line
- About 30-minute drive from Shin-Kurashiki Station of the Sanyo Shinkansen Line
- About 20-minute drive from Kamogata Interchange of Sanyo Expressway
- About 60-minute drive from Okayama Airport
- About 60-minute drive from Hiroshima Airport

- Sanyo Shinkansen
- Sanyo Main Line
- National Route 2
- Sanyo Expressway
- Seto Chuo Expressway

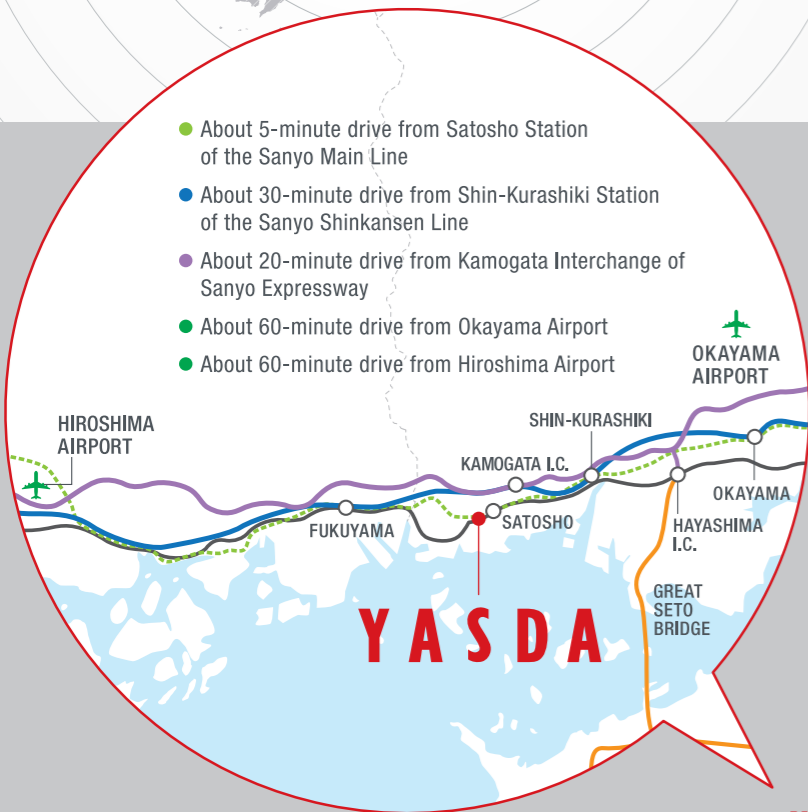

- About 2 hours and 20 minutes by airplane and car from Tokyo International Airport (Haneda Airport)
- About 3 hours by train and car from Kansai International Airport
- About 3 hours and 20 minutes by airplane and car from Chubu Centrair International Airport

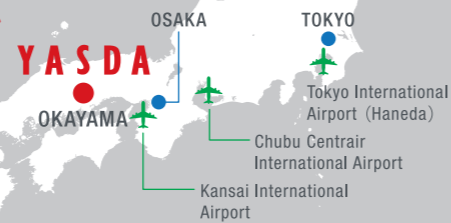

Company name	YASDA Precision Tools K.K.
Head office and factory	1160 Hamanaka, Satosho, Okayama, 719-0303, Japan TEL: +81/865-64-2511 FAX: +81/865-64-4535
URL & E-mail	http://www.yasda.co.jp yasda@yasda.co.jp
Board members	President : Takuto Yasuda Executive Director : Tsuneto Sumida Director : Tokiho Moriya Director : Yoji Tanabe Director : Yasuhiro Hirata Senior advisor : Yukihiko Yasuda Auditor : Eiten Inamura
Incorporated	May 10, 1939
Employees	336
Site area	71,900㎡
Building area	35,500㎡
Business	Machine tools : Machining center, Jig borer, FMC, FMS
Member of association	Japan Machine Tool Builder's Association
Affiliated companies	YASDA PRECISION AMERICA CORPORATION YASDA PRECISION TOOLS (SHANGHAI) K.K



HISTORY OF YASDA



The History of YASDA

2029 → The 100th anniversary.



Founder: Shinjiro Yasuda
 Born on April 15, 1894, Shijiro Yasda founded Strong Shokai at 4-chrome Kamidori, Kyomachibori, Nishi-ku, Osaka in 1929. The company began as a small cylinder boring factory with only three staff.

1929~1958 The establishment and boring machine period.

1960~1972 The initial stage of the machining center.

1972~1991 The Era of high-precision machining center development begins.

1994~2001 Completion of Mechanical Factory 2.

2004~2009 Completion of Mechanical Factory 2.

2007
Development of the YBM 8T machining center

2008
Development of the YBM 9150V vertical three-axis jig borer

2000
Development of the YBM 10T machining center

1999
Development of the H30i machining center

1989
Development of the Self-adjusting preload spindle

1970
Development of the YPC 50 Production Center, machining center

1992
Development of the YBM 1000N machining center

1976
Development of the YBM 90N Precision Center, mid-size machining center

1968
Sections 1 and 2 of the Sasayama factory are completed.

1962
The Small and Medium Enterprise Agency designates Yasda as, "A model factory for small and medium enterprises." A designation the company receives 5 more times consecutively. Partial completion of the Sasayama factory (head office and factory in Satosho Okayama) allows production to begin. Yasda constructs its first R&D lab at the Tomioka factory.

1961
Completion of Assembly Factory.

1960
YASDA joins the Japan Machine Tool Builders' Association.

1944
The factory relocates to Kasaoka Town (current Kasaoka City), Oda District, Okayama, due to forced company relocation during the war. And the company is renamed to 'YASDA Precision Tools K.K.'.

1939
Shinjiro Yasuda reorganizes his business to form 'Strong Shokai K.K.'.

1933
The company attracts attention as the first non-automobile manufacturer in Japan to develop and sell automobile engine pistons.

2013
Development of the YBM 7Ti five-axis machining center

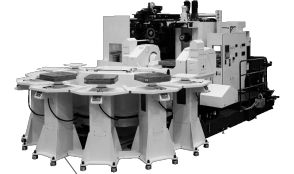

2008
Development of the YBM 8T-TT five-axis machining center



2000
Development of the YASDAMIIPS control system



2000
Development of the YBM 950V CNC jig borer



2008
Development of the YBM Vi40 vertical five-axis jig borer



2002
Development of the YMC 325 micro center



2002
Development of the YBM 6T machining center



2014
Development of the PX30i



2009
Development of the YMC 430 micro center



2010
Development of the GT130 CNC gear grinding machine



2016
Development of the YMC 650



2002
Development of the YBM 900N-TT five-axis machining center

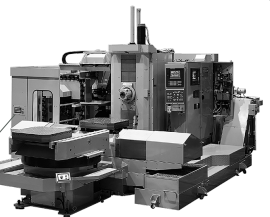

1992
Development of the YBM 1000N machining center

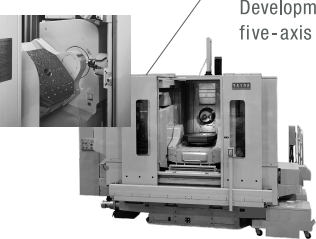

1989
The 60th anniversary.

1986
Completion of the Head Office constant temperature assembly factory.

1983
Yasda closes a licensing agreement of the manufacturing technology for the YPC30 machining center with the company Bridgeport in the UK. Yasda is awarded the Science and Technology Director Award.

1980
The Head Office building expansion is completed.

1979
The 50th anniversary.

1976
Yukihiko Yasuda is re-elected as company president. Tomohiko Yasuda is appointed vice-president Shinjiro Yasuda as chair, and Sadae Yasuda as vice-chair.

1971
Smaller Enterprises Research Center Award.

1970
Shinjiro Yasuda was awarded "The Order of the Rising Sun with Gold and Silver Rays Award" from the government for the development of a boring machine. Yasda forms a Technological partnership agreement with Sundstrand Corporation for a spindle tool retaining system and relevant tools.

1969
YASDA relocates its head office and factory to the new Sasayama complex in Satosho Town (Okayama). The decision is made to separate the jigs and services department, and the company establishes YASDA Technological Services at the Tomioka factory.

1977
Development of the YPC 45 electrically integrated production center with built in NC



1984
Development of the YBM 120N machining center

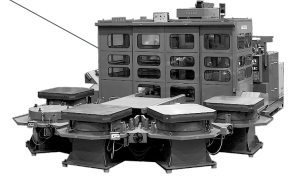

1994
Development of the YBM 600N machining center



1988
Development of the YBM 8120V CNC jig borer



1998
Development of the GT30 CNC gear grinder



1998
Development of the YBM 1218V CNC jig borer



1996
Development of the YBM 660N machining center



2006
Development of the YBM 7T machining center



2004
Development of the H40i machining center



2006
Development of the YBM 15T machining center

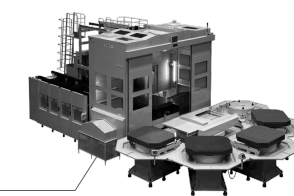

2012
Development of the YBM 10T-100TT five-axis machining center

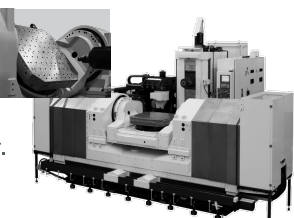

2007
Yukihiko Yasuda receives "The Order of the Rising Sun, Gold Rays with Rosette Award" from the government for the development and production of high precision machining centers. The YBM50J-S Jig Master was awarded "The Best Technical Award" by the Museum of Industrial Technology at the Nippon Institute of Technology.

2009
The 80th anniversary. Factory 3 (constant temperature controlled assembly factory) is completed. Takuto Yasuda is appointed company president, and Yukihiko Yasuda is elected executive director.

2011
YASDA opens its Dongguan Office (Shanghai, China).

2012
YASDA opens its Dalain Office (Shanghai, China).

2016
The 3rd Factory is expanded, and the 2nd Factory's new assembly and shipment lines are completed.

2017
Factory 5 is completed.

1968
Development of the YMC 180 Acratour large machining center

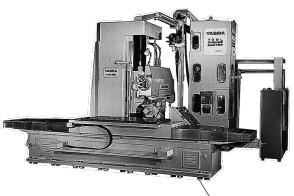

1966
Development of the YBM 80NR the first machine with an NC (Numerical Control System)

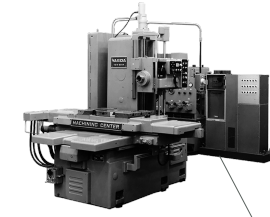

1964
Development of the YBM 50J horizontal high-precision boring machine (Jig Master)

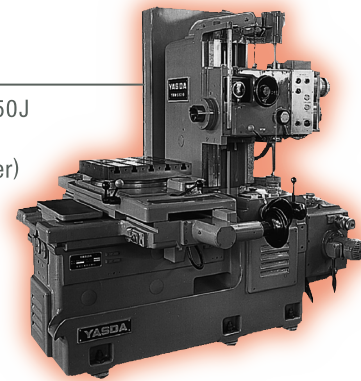

1961
Development of the automatic honing machine

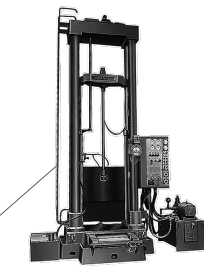

1954
Development of the 102 type cylinder boring machine for recycling small engines

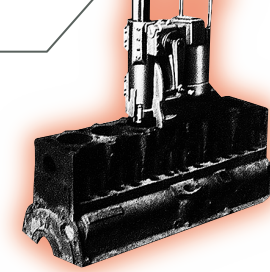

1939
Development of the first boring machine